

## CAST IRON GLOBE VALVES-BS 5152

PN 10, PN 16

### SPECIFICATIONS

STRAIGHT PATTERN, BOLTED BONNET, O/S & YOKE TYPE, RISING STEM, FLANGED ENDS AS PER BS 4504/DIN 2532 OR 2533-AS APPLICABLE

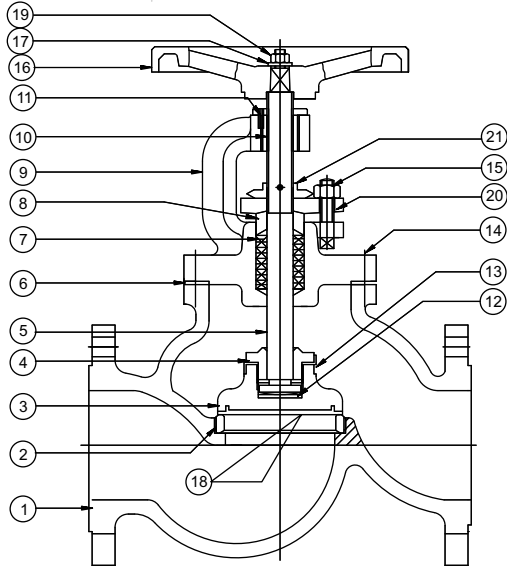

### STANDARD MATERIAL COMBINATION

Part No.	QTY.	DESCRIPTION	MATERIALS	
			Cu-ALLOY TRIM	S.S. TRIM
1	1	BODY	C.I. TO EN 1561 Gr. GJL200	C.I. TO EN 1561 Gr. GJL200
2	1	BODY SEAT RING	Cu-ALLOY TO EN 1982 Gr. CC491K	S.S. TO BS 970 Gr. 410 S21/ASTM A182 Gr. F6a/ASTM A276-410 OR THEIR Eq.
3	1	DISC	Cu-ALLOY TO EN 1982 Gr. CC491K	S.S. TO BS 970 Gr. 410 S21/ASTM A182 Gr. F6a/ASTM A276-410 OR THEIR Eq.
4	1	STEM NUT	Cu-ALLOY TO EN 1982 Gr. CC491K	S.S. TO BS 970 Gr. 410 S21/ASTM A182 Gr. F6a/ASTM A276-410 OR THEIR Eq.
5	1	STEM	BRASS TO BS 2874 CZ114 OR EN 12165 CW721R	S.S. TO BS 970 Gr. 410 S21/ASTM A182 Gr. F6a/ASTM A276-410 OR THEIR Eq.
6	1	GASKET	C.A.F. TO BS 1832	C.A.F. TO BS 1832
7	-	GLAND PACKING	TO SUIT SERVICE CONDITIONS	TO SUIT SERVICE CONDITIONS
8	1	GLAND FOLLOWER	Cu-Alloy to EN 1982 Gr. CC491K	S.S. TO BS 970 Gr. 410 S21/ASTM A182 Gr. F6a/ASTM A276-410 AISI 410
9	1	BONNET	C.I. TO EN1561 Gr. GJL 200	C.I. TO EN1561 Gr. GJL 200
10	1	YOKE BUSH	AL. BRONZE TO EN 1982 Gr. CC333G	AL. BRONZE TO EN 1982 Gr. CC333G
11	2	LOCKING SCREW	CARBON STEEL	CARBON STEEL
12	1	THRUST PLATE	HARDENED STEEL	HARDENED STEEL
13	1	LOCKING WASHER	BRASS	STAINLESS STEEL TO AISI304
14	TO SUITE	STUDS & NUTS	CARBON STEEL TO BS916	CARBON STEEL TO BS916
15	2 EACH	T-HEAD BOLTS & NUTS	CARBON STEEL (MIN. UTS 392 N/mm <sup>2</sup> )	S.S. TO BS 970 Gr. 410 S21/ASTM A182 Gr. F6a/ASTM A276-410 OR THEIR Eq.
16	1	HAND WHEEL	C.I. TO EN1561 Gr. GJL 200	C.I. TO EN1561 Gr. GJL 200
17	1	WASHER	CARBON STEEL	CARBON STEEL
18	1	DISC RING	CAST IRON TO EN 1561 Gr. GTL 200 Cu-ALLOY TO EN 1982 Gr. CC491K	CAST IRON TO BS 1452 Gr.220 S.S. TO ASTM A 182 Gr. F6a OR THEIR Eq.
19	1	NUT FOR HAND WHEEL	CARBON STEEL	CARBON STEEL
20	1	GLAND FLANGE	C.I. TO EN 1561 Gr. GJL 200	C.I. TO EN 1561 Gr. GJL 200
21	1	INDICATOR	GM	BS EN1982 : 99 Gr. CC419K

NOTE: The above data is subject to change without notice due to our continuing product improvement program.

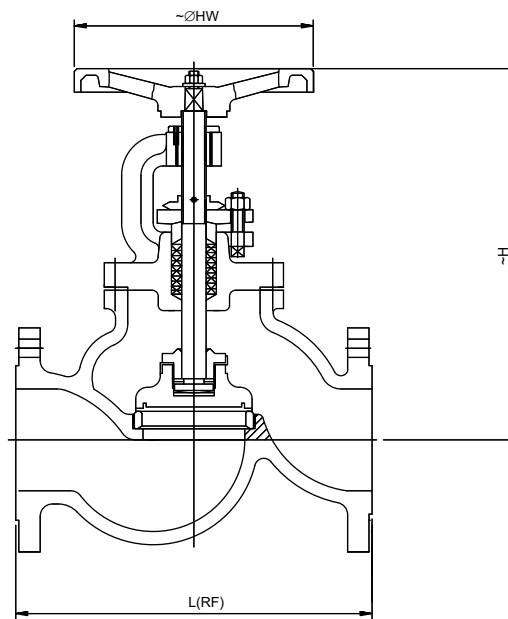

FIG. NO. CI014/CI015/CI052

### CATALOGUE FIG. NOS.

ITEM	FIG. NO.	END DETAILS
CAST IRON GLOBE VALVE PN 16 (S.S. TRIM)	CI 014 RF	FLANGED ENDS TO DIN 2533 PN-16 RF
CAST IRON GLOBE VALVE PN 10 (S.S. TRIM)	CI 015 RF	FLANGED ENDS TO DIN 2532 PN-10 RF
CAST IRON GLOBE VALVE PN 10 (Cu-ALLOY TRIM)	CI 052 RF	FLANGED ENDS TO DIN 2532 PN-10 RF

### PRESSURE / TEMPERATURE RATINGS TO BS 5152

NOMINAL PRESSURE	MAX. PERMISSIBLE GAUGE WORKING PRESSURE °C				
	-10 TO 120°C	150°C	180°C	200 °C	220 °C
PN 10	10 bar	9.2 bar	8.5 bar	8.0 bar	8.0 bar
PN 16	16 bar	14.8 bar	13.9 bar	13.0 bar	13.0 bar

### DIMENSIONAL DATA

DN NPS	15 1/2	20 3/4	25 1	32 1 1/4	40 1 1/2	50 2	65 2 1/2	80 3	100 4	125 5	150 6	200 8	250 10	300 12
L (RF)	130	150	160	180	200	230	290	310	350	400	480	600	730	850
H	165	165	170	200	230	255	305	320	350	405	460	585	640	710
~ØHW	120	120	120	120	140	140	180	180	235	260	320	400	400	400

ITEM CODE NOS.	Aprox. Wt. ^														
	PN 10 (S.S. TRIM)	CI 015 D	CI 015 F	CI 015 G	CI 015 H	CI 015 I	CI 015 J	CI 015 K	CI 015 L	CI 015 N	CI 015 O	CI 015 P	CI 015 R	CI 015 S	CI 015 T
	Aprox. Wt. ^														
	PN 10 (Cu-ALLOY TRIM)	CI 052 D	CI 052 F	CI 052 G	CI 052 H	CI 052 I	CI 052 J	CI 052 K	CI 052 L	CI 052 N	CI 052 O	CI 052 P	CI 052 R	CI 052 S	CI 052 T
	Aprox. Wt. ^														
PN 16 (S.S. TRIM)	CI 014 D	CI 014 F	CI 014 G	CI 014 H	CI 014 I	CI 014 J	CI 014 K	CI 014 L	CI 014 N	CI 014 O	CI 014 P	—	—	--	

### TEST PRESSURES

NOMINAL PRESSURE RATING	SHELL TEST (HYDROSTATIC)	SEAT & BACK SEAT TEST (HYDROSTATIC)	STANDARD NO.
PN 10	15 bar	10 bar	BS5152
PN 16	24 bar	16 bar	

NOTE: The above data is subject to change without notice due to our continuing product improvement program.

(^WEIGHT GIVEN IN KGS)